

- > The power package in the dispatch department and warehouse
- > The display device is well-protected by a metal frame
- > Due to the optimized loads rollers it is easier to get over rough ground



Pallet truck scales

Weighing and transporting – just one operation

Speed up your warehouse and dispatch processes with the KERN pallet truck scales.







Get the exact weight of a load and at the same time, transport it to a specific location, all in one operation. This reduces commissioning times and avoids queues in front of fixed floor scales.

These mobile weighing solutions are space-saving and deliver reliable weighing results. Differences between given and actual weights can be determined quickly e.g. in the goods-in and out department. This uncovers inaccurate quantities, saves time and money and therefore ensures a very short amortisation period of the scales original cost.

KERN pallet truck scales are of robust industrial quality, with high-level protection against dust and water splashes, with high-contrast, easy-to-read displays as well as solid wheels and load rollers – all this helps to give you practical support in your work – day after day.

Of course, all KERN pallet truck scales can also be calibrated and delivered with a DAkkS calibration certificate (optional). This ensures the high level of accuracy of your pallet truck scale.

Quick-Finder Pallet truck scales

Readability	Weighing capacity [Max]	Model	Page	 DAYS	 CAL EXT	 SUM	 IP	 BATT	 ACCU
[d] kg	kg	KERN							
1	2000	VHB 2T1	147	2	●	●	●	●	○

For an explanation on the pictos, see front flap

● = standard ○ = option

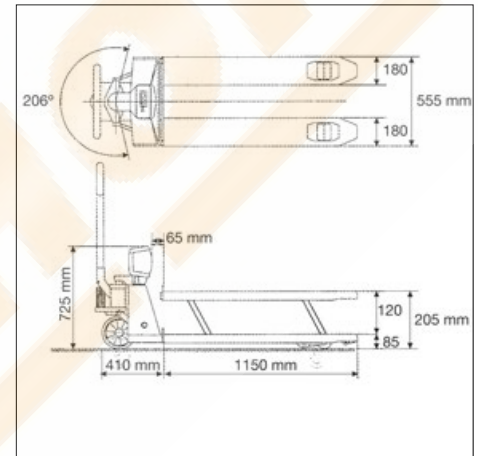

Pallet truck scale with complete protection against dust and water splashes IP65/67 and a memory for a container weight

Features

- PRE-TARE function for manual subtraction of a known container weight, useful for checking fill-levels
- **1** Display device: plastic, protection against dust and water splashes IP65
- **2** Load fork: Protection against dust and water splashes IP67, temporary use in wet areas possible
- Pivot range 206°
- Castors: Solid rubber on aluminium rims
- **3** Load rollers: Tandem tyres to overcome thresholds and obstacles more easily
- Totalising of weights
- Ready for use: Batteries included, 4×1.5 V AA, operating time up to 80 h

Technical data

- Large LCD display, digit height 28 mm
- Permissible ambient temperature -10 °C/40 °C

Accessories

- Castors made of red polyurethane on aluminium rims. Ideal for light-coloured flooring as they leave less visible abrasive marks. Suitable for the current models of the pallet truck scale range KERN VHB (when retrofitting, please give the serial number of the pallet truck scale available when ordering), scope of delivery: 1 item, KERN VHB-A02

1 Shipment via freight forwarder. Please ask for dimensions, gross weight, shipping

STANDARD



OPTION



Model	Weighing capacity	Readability	Net weight	Option	
				DAkKS Calibr. Certificate	
KERN	[Max] kg	[d] kg	approx. kg	DAkKS KERN	
VHB 2T1	2000	1	110	963-131	